

INSTRUCTION MANUAL - HIGH CURRENT DRIVER BOARD FEDERAL COMPLIANT VERSION

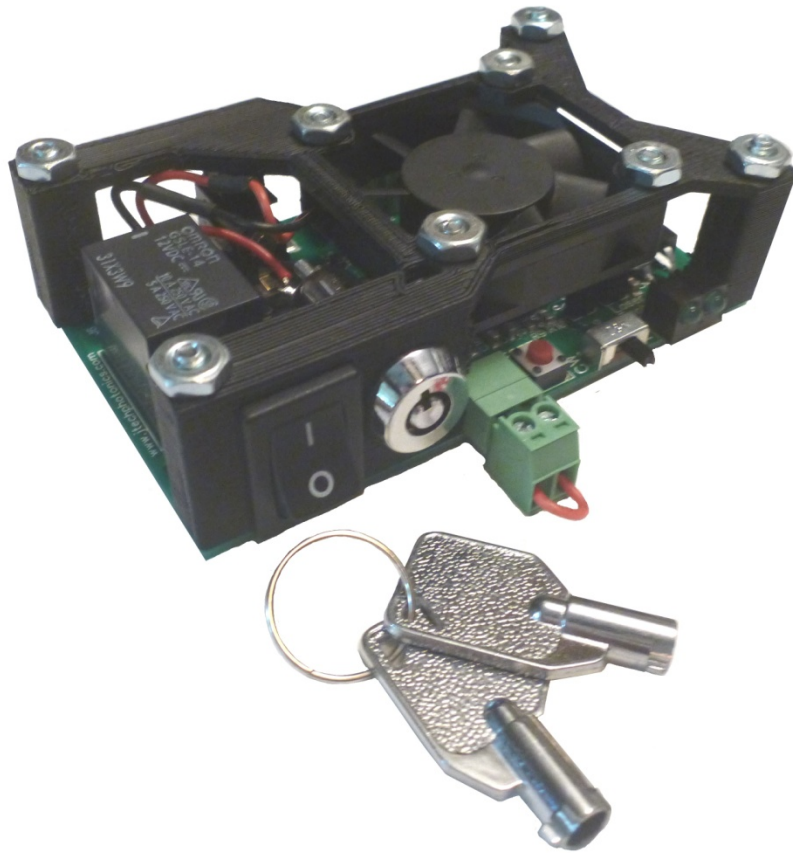

Model

2.5 AMP: HCDBSAFDA2_5AMP

Version: 1.1

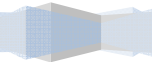



CONTENTS

Instruction Manual - High Current Driver Board Federal Compliant Version.....1

General4

 Overview4

 Specifications4

 Safety.....5

 Disclaimer.....5

Getting Started5

 Unpacking.....5

Operation.....6

 Front of Driver Board6

 Back of Driver Board.....7

 Current Limit Settings and Test Points8

 Input Signal Configuration.....9

 Safety Interlocks.....10

 Safety Features and Reseting the laser driver.....11

 Remote Reset Switch11

 Key Swtich12

 Output Connection.....13

 Mode Selector Switch13

 Control Signal and performance14

 First Operation15

 General Operation.....15

 Current Ranges and Adjusting current16

 Checking the output current on a meter16

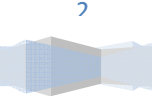



| | |
|--|----|
| Monitoring Current With a microcontroller..... | 18 |
| Connecting the microcontroller..... | 18 |
| writing microcontroller Firmware | 20 |
| adding averaging and glitch removal..... | 21 |
| Compliance Voltage and power adapters | 22 |
| OEM power Supply selection..... | 22 |
| Mounting | 23 |

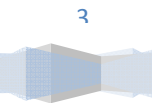

GENERAL

OVERVIEW

This is the fourth generation of the popular High Current Laser Diode Driver series. We designed this new generation to follow the federal guidelines for safety compliance for high power Class 4 laser operation. This includes the use of a key enable switch, safety interlock system, power off reset, and laser LED indicators. All of these features make for a safer laser operation and will comply with federal laws regulating such operations.

At the heart of the product are laser trimmed parallel regulators to give constant current without the large temperature dissipation of other regulators. Couple this with inherent safety features like soft starting, current isolation, reverse protection, ESD protection, and thermal shutdown control and you have all you need in a small package.

The high power laser diode driver is cost effective and easily integrated into industrial, research, or enthusiast projects and products. The driver can be operated in CW mode or in Input Control Mode to be interfaced to remote electronics. This design uses digital isolators for super fast response and input range while protecting the laser from deadly ground loops. The board has screw terminal connections as well as Molex mini-fit Jr. connectors for easy connections to external equipment for control and the laser diode output.

SPECIFICATIONS

| Specification | HCDBSAFDA2_5AMP |
|---|--|
| Current Source Range: | 0 - 2.5 Amps |
| Current Limit Jumper Settings: | 0.5, 1.0, 1.5, 2.0, 2.5 Amps |
| Compliance Voltage w/12V adapter: | 8 volts |
| Current Resolution: | 0.1% |
| Current Adjustment: | Analog Trim Pot |
| Current Range Accuracy | Always greater than limit, no more than 15% |
| Laser Diode Protection: | Soft Start, Reverse Voltage, Current Limit, Thermal Shutdown |
| Integrated Safety Features | Laser Enable Key Switch, Integrated Laser Interlock, Power off Reset, LED Indicators |
| AC Adapter Input Voltage: | 100 - 240 VAC |
| Control Signal Digital Isolation Voltage: | 4500 Vrms |
| Minimum Control Signal "Turn On" Voltage: | 2.8 Volts |
| Control Signal Maximum Voltage: | 36 Volts |
| Control Signal Maximum Current: | 50 ma |
| Control Signal Maximum Frequency: | 5KHz |
| Connectors: | Screw Terminal and Molex Mini-Fit Jr™ Connectors |
| Operating Temperature: | 0 to 40 °C |
| Storage Temperature: | -40 to 70 °C |

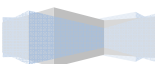

| | |
|-------------|-------------|
| Dimensions: | 3.6" x 2.2" |
|-------------|-------------|

SAFETY

- Operate the High Current Driver Board in an explosion free area.
- The Driver Board may reach high temperatures under operation. Make sure there is adequate airflow to the Driver Board. Also, make sure there is adequate protection around the Driver Board and that it is not in contact with other materials.
- When connected to laser diode components, the output of the laser can be up to several watts of power. Always use proper safety eyewear and laser safety protection when connecting to laser components in your final system. When operated incorrectly the laser component can cause severe damage to eyes and health.

DISCLAIMER

- The High Current Driver board is designed as an OEM product to be integrated into a final solution.
- All statements of safety are only applied when the driver board is used in its intended purpose.
- You are legally responsible for any injury to anybody resulting from the use of or assembly of the driver board or their finished products.
- You Accept this driver board as a COMPONENT for integration in a system of YOUR OWN design and will be legally responsible from any and all LIABILITIES.

GETTING STARTED

UNPACKING

Inspect the shipping container for damage.

Verify the contents of the package:

1 - High Current Driver Board.

2- Key switches

1- Power Adapter with connector according to ordering country or OEM cable.

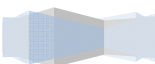

OPERATION

FRONT OF DRIVER BOARD

Front View

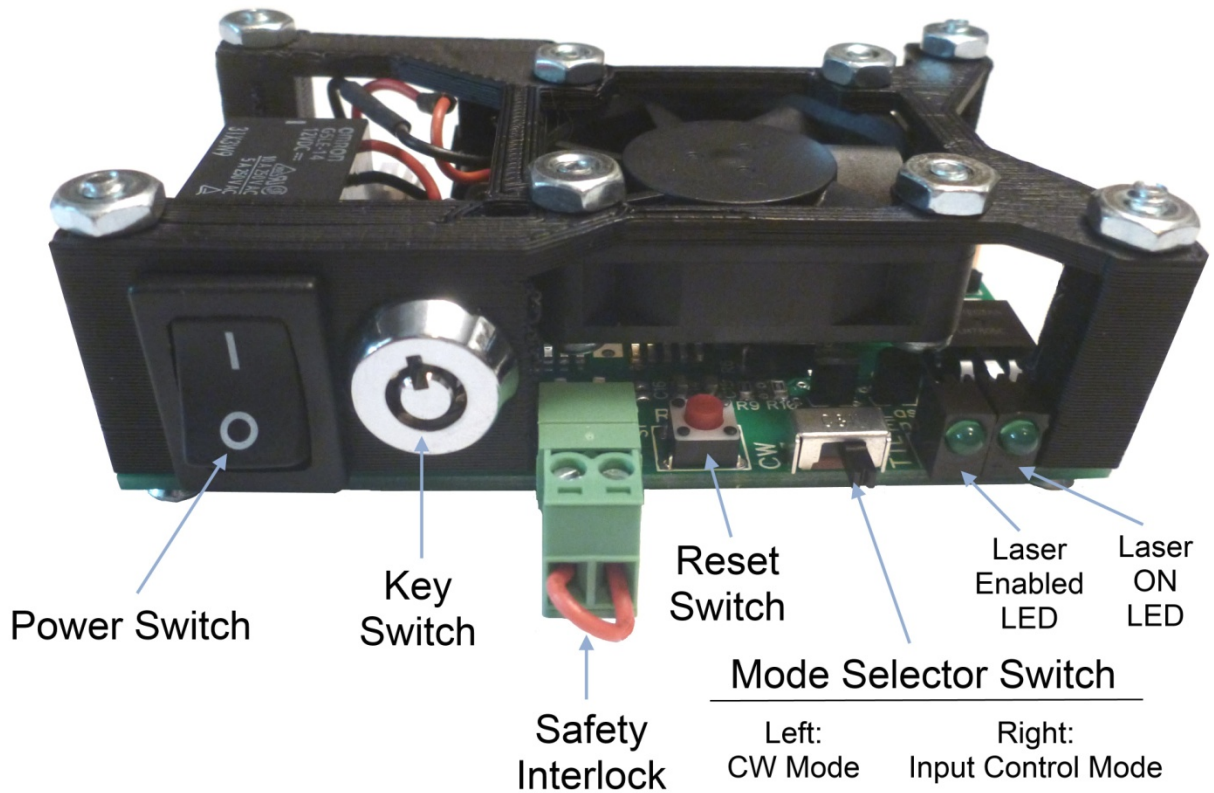

The front contains:

- Power / Enable Switch: Down = OFF, Up = ON
- Laser Enable Key Switch: Key Up = OFF, Key to Right = Enabled
- Safety Interlock: Screw Terminals for "Normally Closed" interlock switches. (shown defeated)
- Reset Switch: Press momentarily to reset interlock and power faults
- Mode Selector Switch: Left = CW Mode, Right = Input Control Mode
- LED Indicators: Left = Laser Enabled, Right = Laser Emission ON

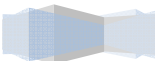

BACK OF DRIVER BOARD



Back View

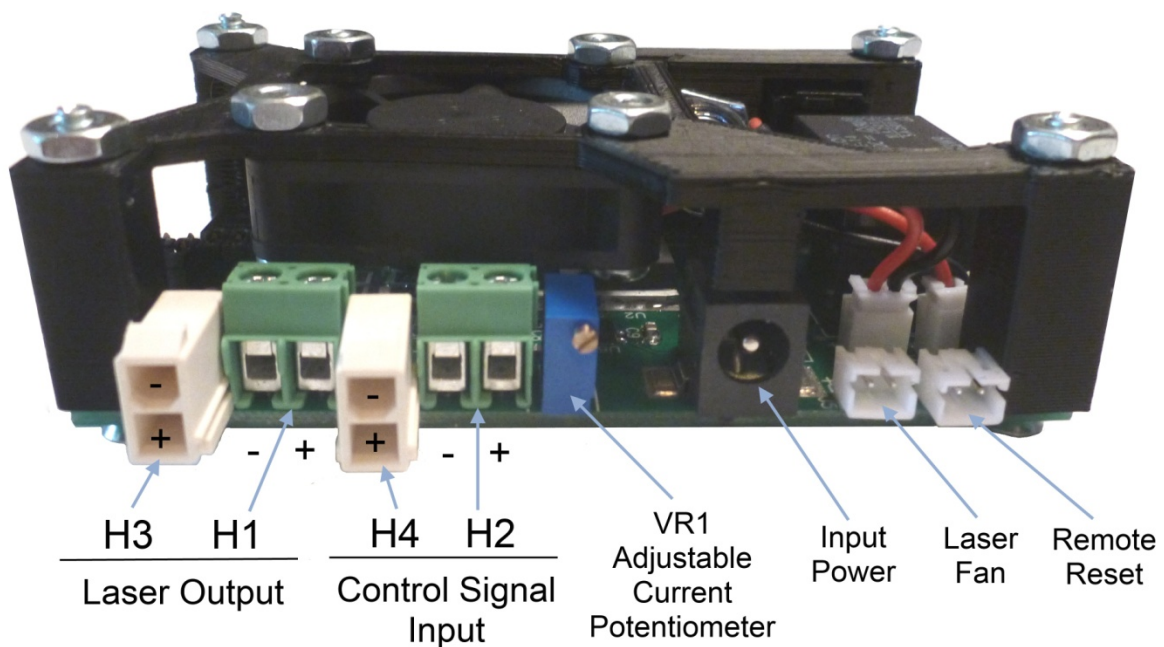

The back contains:

- H3 - Laser / LED Output Connector:
- H1 - Laser / LED Output Screw Terminal:
- H4 - Input Control Connector:
- H2 - Input Control Screw Terminal:
- VR1 - Potentiometer for Analog Current Level
- Power Adapter Plug (center pin positive)
- Laser Fan Connector
- Remote Reset Switch Connector

Top = Negative Output, Bottom = Positive Output
 Left = Negative Output, Right = Positive Output
 Top = Negative Input, Bottom = Positive Input
 Left = Negative Input, Right = Positive Input

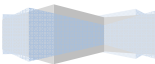

CURRENT LIMIT SETTINGS AND TEST POINTS

Side View

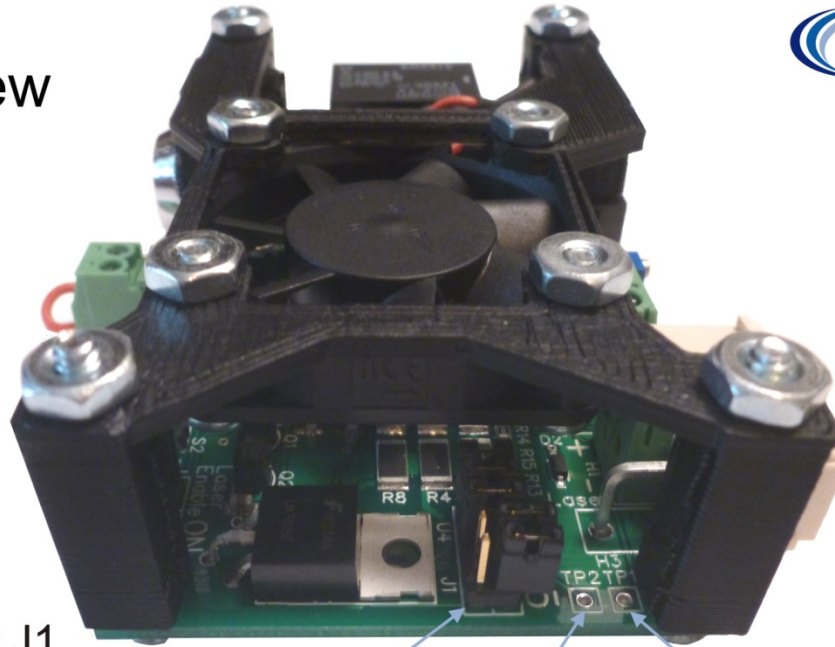

Jumper J1

| Setting | Current Limit |
|-----------|---------------|
| 1 | 0.5A |
| 1&2 | 1A |
| 1&2&3 | 1.5A |
| 1&2&3&4 | 2A |
| 1&2&3&4&5 | 2.5A |

TP2
Voltage at
Laser
divided by 3.61

TP1
Voltage at
Regulator
divided by 3.61

- Jumper J1 Current Limit Selector: This will limit the output current of the driver to the selected level. The maximum level is based on the driver version that was purchased.

| Current Limit (Amps) | Jumper Position On |
|----------------------|--------------------|
| 0.5 | 1 |
| 1 | 1,2 |
| 1.5 | 1,2,3 |
| 2 | 1,2,3,4 |
| 2.5 | 1,2,3,4,5 |

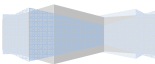

- **Test Points:** These signals provide a connection point to be able to monitor current with a computer or microcontroller. See section "Monitoring Current with Microcontroller" for more details.

INPUT SIGNAL CONFIGURATION

Side View

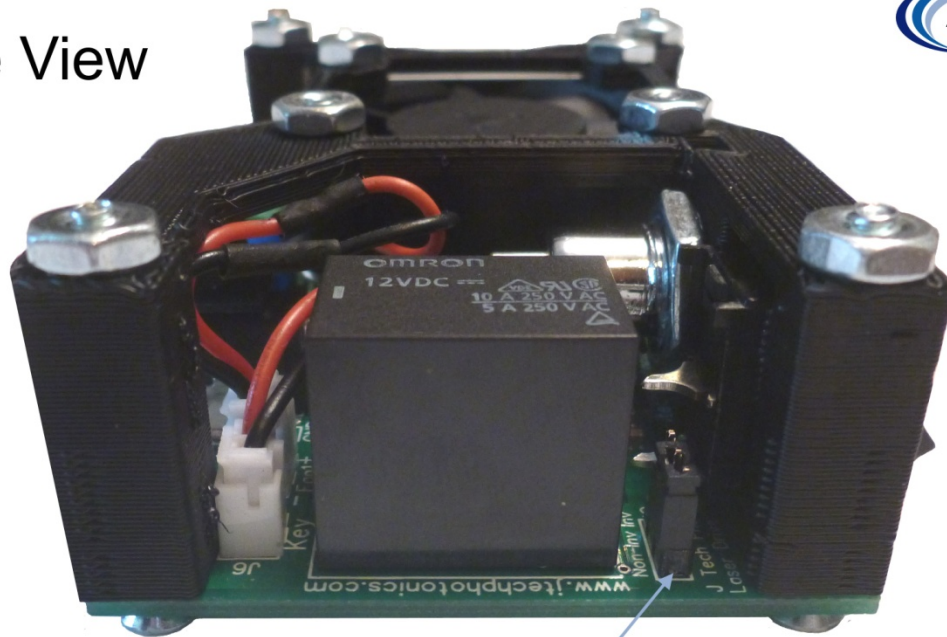

Jumper J3

| Non-Inv: | Inv: |
|--|---|
| Input Control Signal Logic HIGH will turn ON laser | Input Control Signal Logic LOW will turn ON laser |

- **J3 - Control Signal Jumper:** This will either invert or not invert the incoming control signal. When interfacing with equipment that is not under the users control, it is sometimes needed to invert the incoming logic.

Outer Two Jumpers On = Non-Inverting Input
Inner Two Jumpers On = Inverting Input

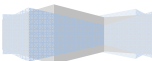

SAFETY INTERLOCKS

The laser driver has an interlock system which is NORMALLY CLOSED and contains a voltage in the cable of 12V supplied by the laser driver board. This means if any switch along the interlock chain becomes OPEN, then the circuit will open and the laser will disengage the laser.

Examples of use of the interlock system include the emergency stop button switch and an enclosure door switch. When integrating the laser driver and laser into an OEM machine, all entrances to the machine (enclosure doors) must have an interlock switch in order to be considered compliant with Class 4 laser rules. Multiple switches can be added along the chain when integrating the laser driver into OEM machines as long as they are wired in series.

Here is an example of an interlock system:



Example Safety Interlock System

Switches are all Normally Closed (NC)

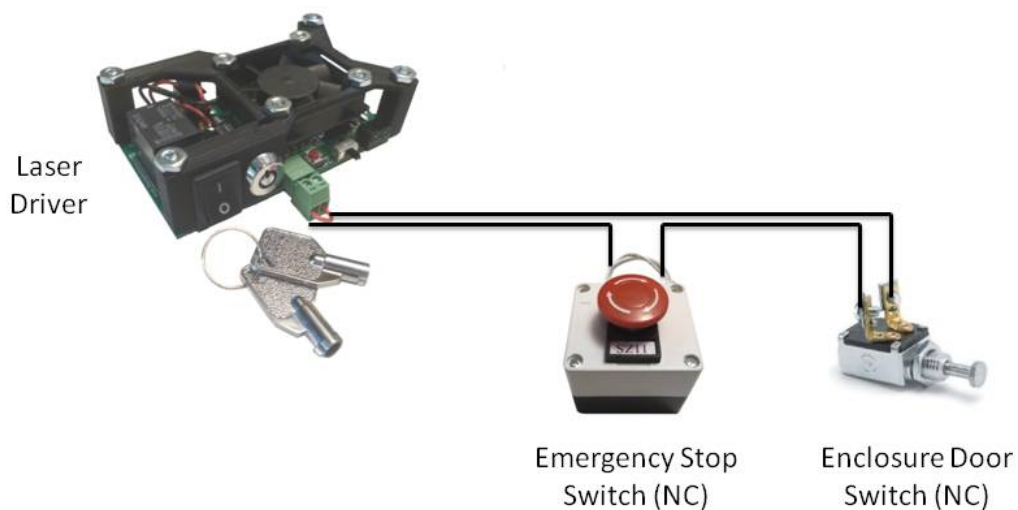

In the example above the switches are connected in series so if ANY of the switches are opened, the interlock will engage.

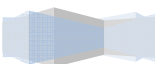

If the laser driver was purchased in a kit including the emergency stop button, it will be wired to the interlock key. If not, then the key will be shipped with a jumper, defeating the interlock system. It is up to the consumer to make sure the interlocks implemented correctly before use of the laser.

SAFETY FEATURES AND RESETING THE LASER DRIVER

The safety features of this laser driver include both a safety interlock and a power monitor to watch for power outages. If either of these features is activated, they will disable the laser and the user **MUST** reset the laser driver to continue operation of the laser. Here are the situations for each of these safety features and how to reset the feature:

Safety Interlock: If the interlock is tripped, either by an emergency stop switch being activated or by an enclosure door switch opening you must:

1. Make sure the situation is clear for laser operation and make sure the laser is not being controlled in an ON position.
2. Clear all switches that have been activated back to the Normally Closed position.
3. Press the reset switch on the board (or remote reset switch if installed)
4. The laser is then ready for use again.

Power Outage Monitor: If the power adapter is either unattached from the laser driver or there is a power outage, then the laser driver will disable the laser. This is in case there is a power outage situation in which the laser was left ON and to prevent unknowing persons being injured when the power comes back on and not realizing the laser was left ON.

1. Make sure the situation is clear for laser operation and make sure the laser is not being controlled in an ON position.
2. Plug back in the power adapter (if it was removed from the board).
3. Press the reset switch on the board (or remote reset switch if installed)

REMOTE RESET SWITCH

The remote reset switch option allows for placement of another reset switch to a more convenient location, like the front of the machine for example. The switch can be mounted on a panel and attached tight with the provided locking nut. Attach the connector to the back of the driver board on the farthest right connector.



KEY SWITCH

The laser driver includes a key switch to enable or disable the laser. This is a requirement for Class 4 laser operation. The key is only removable in the "unlocked" position with the key facing up. The key can then be stored in a safe place to prevent unwanted use of the laser by children or others who are not authorized to use the equipment.

When the key is turned clockwise to the right, the laser will be enabled. The key cannot be removed when the laser is enabled. The laser driver can be turned off with the power switch while the key is still in the Enabled position.

The key can sometimes be a bit difficult to turn so be gentle with it as it might break away the plastic housing if forced.

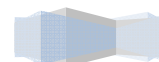

OUTPUT CONNECTION

A typical connection for a laser diode or LED will be:

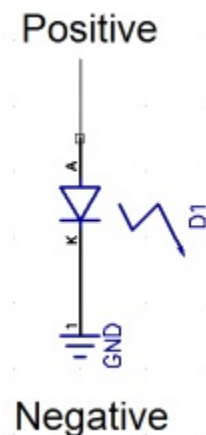

If you purchased the laser driver in a kit with a laser, it will have a molex mini fit connector that will attach to connector "H3".

MODE SELECTOR SWITCH

The driver board has a selector switch for the two different modes of the board.

- **Input Control Mode:** This is when the switch is on the RIGHT. This mode allows for a signal to be connected to connectors H2 or H4 for a signal to turn the laser on and off. Use this input with your controller to turn the laser on and off with G Code commands.
- **CW Mode:** This is when the switch is on the LEFT. This mode stands for "Constant Wave", which means that the laser will turn on and stay on until the switch is turned back to the right or the power on the board is turned off.

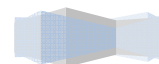

CONTROL SIGNAL AND PERFORMANCE

The input connection provides an optically isolated input for control of the laser diode. The connection and the jumper settings were described in the previous sections. The voltage required to turn on the opto-isolator is 2.8 volts. The input can handle up to 36 volts. The input can be cycled with no degradation up to 5KHz. It will work with 3.3V, 5.0V and 12V, 24V logic boards from various manufacturers like National Instruments.

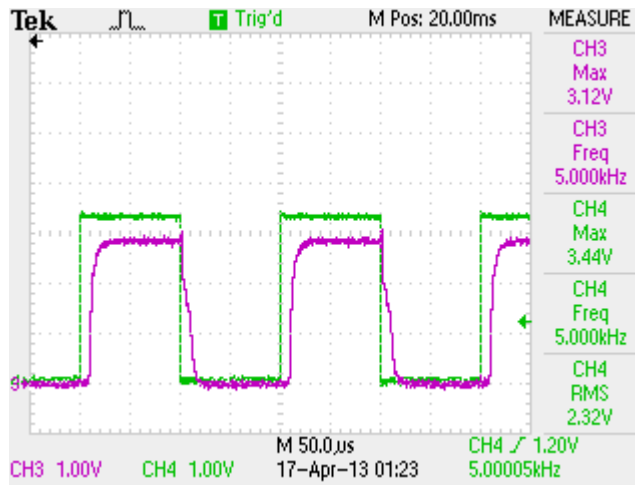

Typical Control Signal with "non inverting" set running at 5KHz. Ch 1 control, Ch 3 output.

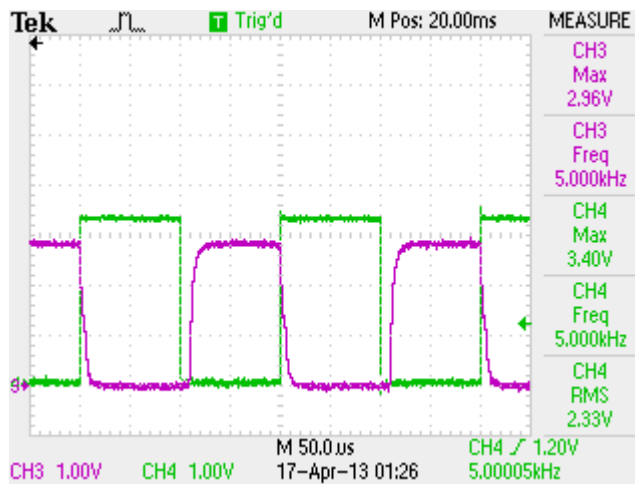

Typical Control Signal with "inverting" set running at 5KHz. Ch 1 control, Ch 3 output.

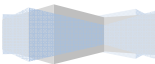

FIRST OPERATION

- **Before operation read the Safety section of this manual.**
- Properly connect the output of the driver to the laser or LED to be driven. Ensure the connections are correct.
- If using input control, connect the input signal to the driver board.
- Make sure the jumpers are correctly set for current limit and input control to the desired settings.
- Plug in the adapter to the AC power.
- Plug in the adapter to the Driver Board.
- Make sure the safety interlocks are correctly assembled or the defeat jumper is on the interlock key.
- Press the RESET button on the driver board. You should hear an audible "click" which is the safety relay connecting. If you do not hear a click, check your interlock circuit and make sure the driver has power.
- Push the power switch to the ON position.
- Turn the key switch clockwise to the ENABLED position
- Your driver is now ready to produce current for your laser. If in CW mode, the "enabled" and "laser on" LEDs will light up and the output will be enabled. If in input control mode and the input signal is not enabled, the "enabled" LED will only light up. When the input control signal gets enabled, the "laser on" LED will light up and the driver output will be enabled.

GENERAL OPERATION

- Laser Diodes and LEDs are meant to be driven within their specifications. Degradation of the diode will occur when diodes are overdriven beyond their specifications.
- Keeping laser diodes on for a long continuous time will degrade the diode if thermal issues are not addressed.
- The high current driver board will reach high temperatures if the board is continuously driving high current for long durations. Make sure it has adequate airflow.
- Keep the driver board in a well ventilated area.
- Using the Mode Selector Switch as an ON/OFF switch for the laser:
 - Make sure Jumper J3 is on "non inverting".
 - When there is no input control, you can keep the power switch on and use the Mode Selector Switch to control the output of the laser.

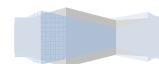

CURRENT RANGES AND ADJUSTING CURRENT

There are two sets of adjustment for controlling the current output. There are the current limit jumpers and the potentiometer. The current limit jumpers are J1 and have the "1 2 3 4 5" on them will set the MAX current the board can provide with the potentiometer set to FULL (all the way turned clockwise). The numbers are in 500ma increments:

- 1 - 500ma limit
- 1&2 - 1amp limit
- 1&2&3 - 1.5 amp limit
- 1&2&3&4 - 2 amp limit
- 1&2&3&4&5 -2.5 amp limit

Having all five jumpers on gives a maximum of 2.5 amps possible. Having three jumpers on gives a maximum of 1.5 amps. We recommend keeping it below the maximum current for your laser diode if you don't want the possibility of overdriving the laser which will probably kill it quickly.

Set the jumper on J1 to the appropriate range you desire to drive the diode. For example, a 1Amp range will have the jumper 1 and 2 on. This will give an output current of greater than 1 Amp within 10% (with the potentiometer VR1 completely turned counter-clockwise.)

To get a specific current, adjust the potentiometer VR1 with a small flat head screwdriver.

- To **REDUCE** current, turn counter clockwise
- To **INCREASE** current, turn clockwise

To get exactly 1 Amp of current, adjust the potentiometer VR1 counter counter-clockwise to decrease the current to the diode and clockwise to increase the current to the diode.

The potentiometer has 21 turns of adjustment and can achieve a resolution of 1% or better.

CHECKING THE OUTPUT CURRENT ON A METER

We recommend using a current meter to check the output of the driver board before hooking up the laser to verify the output is within the limits of operation of the diode laser. This is a very useful tool when adjusting the current to a specific value with the potentiometer.

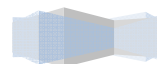



Klein Tools Digital Multi-meter

HOME Depot Model # MM1000 Internet # 202521270 Store SKU # 362878



Alternatively, you can use a clamp style meter to check the current on the output wire to the laser. This method is normally not as accurate as the multi meter but can provide a view of the current as the laser is in operation.

Depending on your laser efficiency you can estimate the output power of the diode. Many lasers are 1:1 for current to Watts. For a laser with a high output G2 lens, the ratio is 1:3.

To check the current of the board with a multi-meter, simply connect the test leads of the multi meter to the output connector from the laser driver. Always check the current **WITHOUT** the laser connected! Because you are connecting your meter test leads to the output connector they may make spurious connections causing power spikes and will be sent to the laser diode directly bypassing the safety protection features of the laser driver board. You can adjust the current here using the potentiometer. This is shown in the following picture:

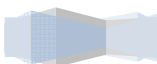

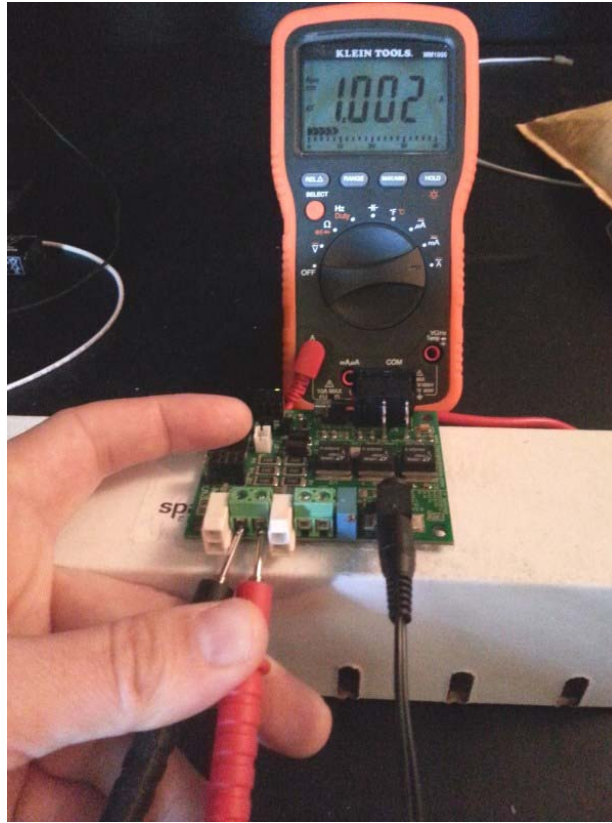

Checking output current with Multi-meter. Laser Diode is **UNPLUGGED** for this procedure.

MONITORING CURRENT WITH A MICROCONTROLLER

There are current sense resistors and test points on the board specifically to get the voltage across the high current resistors from both the regulator side as well as the laser side. Looking at this voltage will give an “on the fly” level of what is happening on the board at all times. The laser driver board runs at 12V, but the connections to these test points are voltage divided to be able to work with 3.3V micro-controllers (it can also work with 5V ones by changing the level in firmware).

CONNECTING THE MICROCONTROLLER

On the laser driver board there are two test points, TP1 and TP2. These test points provide measurement connections for the voltage at the regulators (one side of the current resistors) and at the laser output (the other side of the current resistors).

First you need to connect some wires:

- Connect TP1 to analog input #1 in the micro
- Connect TP2 to analog input #2 in the micro
- Also, you might need to connect the GND on the laser driver to the GND on the micro-controller, but possibly not. You can also connect the GND to the AREF pin and set the analog reference to “external” to

get a clean signal from the laser board without causing a ground loop. The ground test point is located just right of the power input connector looking from the back of the board.

Set up your code to make the pins you selected analog inputs. Now you can read in the voltage on the pins with your micro-controller.

So now that we have the physical connections done, let's get to the theory on how to get the current value from the voltage across a resistor. From high school physics class, the equation to get current is:

$$I = V / R$$

Which is the voltage over the current resistor divided by resistance. Considering there are multiple current limit settings, it will change the amount of resistance for the equation. So, here is a table with the resistances for the different jumper settings:

| Current Limit | Jumper Setting | R Value |
|---------------|----------------|---------|
| 0.5 | 1 | 5.5 |
| 1 | 1&2 | 2.75 |
| 1.5 | 1&2&3 | 1.83 |
| 2 | 1&2&3&4 | 1.38 |
| 2.5 | 1&2&3&4&5 | 1.1 |

So now the equation is:

$$I = (TP1 - TP2) / R \text{ Value}$$

The board outputs voltage at the TP1 and TP2 points divided by 3.61. This was done so the board would have a MAXIMUM voltage of 3.3V to be able to fit in the range of a 3.3V microcontroller input (12V / 3.61 = 3.3V). We now have to take this into account in our equation:

$$I = ((TP1 - TP2) * 3.61) / R \text{ Value}$$

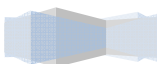

WRITING MICROCONTROLLER FIRMWARE

The micro controller is a bit different in the input reading. It will take a voltage and turn it into a number between 0 and 1023. Remember, the TP1 and TP2 voltages are divided in a resistor network before the micro-controller to make sure the maximum value on the driver board will be below 3.3V (the maximum of many microcontroller inputs). The microcontroller will also read in with a A/D and give a value in the resolution of that A/D. Let's take the example of an Arduino board which have a 8 bit resolution on the analog inputs, so it will be 1024 levels (actually 1023 levels because you start at zero).

Let's start with some code: Let's assume you chose pin A0 for TP1 input and A1 for TP2. So, we now have to convert to get the real voltage at the input in the micro controller:

```
// read the input on analog pin 0:  
int TP1Value = analogRead(A0);  
  
// Convert the analog reading (which goes from 0 – 1023) to a voltage (0 – 3.3V):  
float voltage1 = TP1Value * (3.3 / 1023.0);  
  
// read the input on analog pin 1:  
int TP2Value = analogRead(A1);  
  
// Convert the analog reading (which goes from 0 – 1023) to a voltage (0 – 3.3V):  
float voltage2 = TP2Value * (3.3 / 1023.0);
```

So, now you need to convert back to the 12V level of the board (you can do this in the previous lines but want to just make it explicit for instruction):

```
// Convert the analog reading of a voltage (0 – 3.3V) to (0 – 12V):  
float voltage1_12V = voltage1 * 3.61;  
  
// Convert the analog reading of a voltage (0 – 3.3V) to (0 – 12V):  
float voltage2_12V = voltage2 * 3.61;
```

Now all you have to do is determine the R Value and calculate I: (from the previous example we will use 1.5amp limit jumpers with R value of 1.83)

```
// Calculate the current based on the current limit jumper setting:  
float current = ( voltage1_12V – voltage2_12V ) / 1.83 ;
```

If you leave your current limit setting always the same, you can hard code it, or better yet make it a variable that can change depending on the jumper setting you are using on the board.

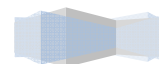

ADDING AVERAGING AND GLITCH REMOVAL

Now that you have some code written for calculating current from the input voltage, let's think about hooking this up to a display (like an LCD or USB to the computer). If you want to show it on an LCD, you probably will need to average out the readings because the LCD display will only update so fast. Also, you might have some glitches in your readings if it is a noisy environment, so averaging and throwing out outliers is a good idea.

Here is a function that will return the average current reading and can be called by the LCD display function:

```
float GetAvgCurrent() {  
  
    float CurrentValue = 0;  
    float CurrentValueAvg = 0;  
    float TP1Value = 0;  
    float TP2Value = 0;  
    i = 0;  
  
    while ( i < 250 ) {  
  
        TP1Value = analogRead(A0);  
        TP2Value = analogRead(A1);  
  
        //Calculate current for jumper setting 1.5amps  
        CurrentValue = (( TP1Value - TP2Value ) * 3.61 * ( 3.3 / 1023 ) ) / 1.83 ;  
  
        //For normal reading over 0 set it in the average  
        if (CurrentValue > 0){  
  
            CurrentValueAvg = (CurrentValueAvg + CurrentValue)/2;  
  
            i++;  
        }  
  
        //catch the glitches that say are negative and make them zero  
        else {  
  
            CurrentValue = 0;  
            CurrentValueAvg = (CurrentValueAvg + CurrentValue)/2;  
            i++;  
  
        }  
  
    }  
  
    return (CurrentValueAvg);  
}
```

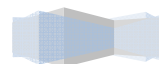

COMPLIANCE VOLTAGE AND POWER ADAPTERS

Depending on the compliance voltage of the laser diode, it is preferable to choose the correct power adapter to meet the needs of the laser while minimizing excess voltage dissipated as heat across the regulators.

There are several AC/DC wall adapters in the accessories section of www.jtechphotonics.com to choose from, or you can purchase your own. The requirements are:

- AC to DC current
- Positive center
- 2.1mm I.D. x 5.5mm O.D
- Female

OEM POWER SUPPLY SELECTION

If you purchased the OEM version of the laser driver, you can either purchase your own adapter or connect it to your own power supply. For integration into other systems, it is advisable to use the system power supply as long as it is in the range of the laser diode you are driving.

It is necessary to choose a power supply that will have enough voltage to run the laser diode at maximum current as well as be not more than a few volts over the compliance of the laser diode. Any additional voltage above the compliance voltage of the laser diode will be dissipated as heat. Excessive additional voltage can lead to overheating of the laser driver. To figure out how much voltage is needed for a minimum, take the compliance voltage of the laser diode and add the voltage drop from the laser driver.

The voltage drop for the laser drivers are:

- HCDBSA 1.0 Amp : 1 Volt Drop
- HCDBSA 2.0 Amp: 3 Volts Drop
- HCDBSA 2.5 Amp: 3 Volts Drop

Minimum Power Supply Voltage = Laser Diode Compliance Voltage + Laser Driver Voltage Drop

For example, the 445nm laser diode component has a compliance voltage of 5.5 volts at 1.7 amps. Using a HCDBSA 2.0 Amp driver, the minimum power supply needed is:

$$8.5 \text{ volts} = 5.5 \text{ V} + 3 \text{ V}$$

A power supply above 8.5 volts and not more than 12 volts should be chosen to stay within the thermal limits of the laser driver.

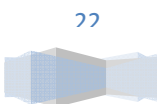

MOUNTING

The following drawing is provided for mounting. Units are in inches.

